

SPEEDLITE 540EZ

C50-0711,2

PARTS CATALOG

ATTENTION: these documentations are published only for purpose of study and search, they are not published for purpose of profit, all the rights and relative copyrights are of the respective owners. **Free documentation not to sell.**

CANON SPEEDLITE 540EZ

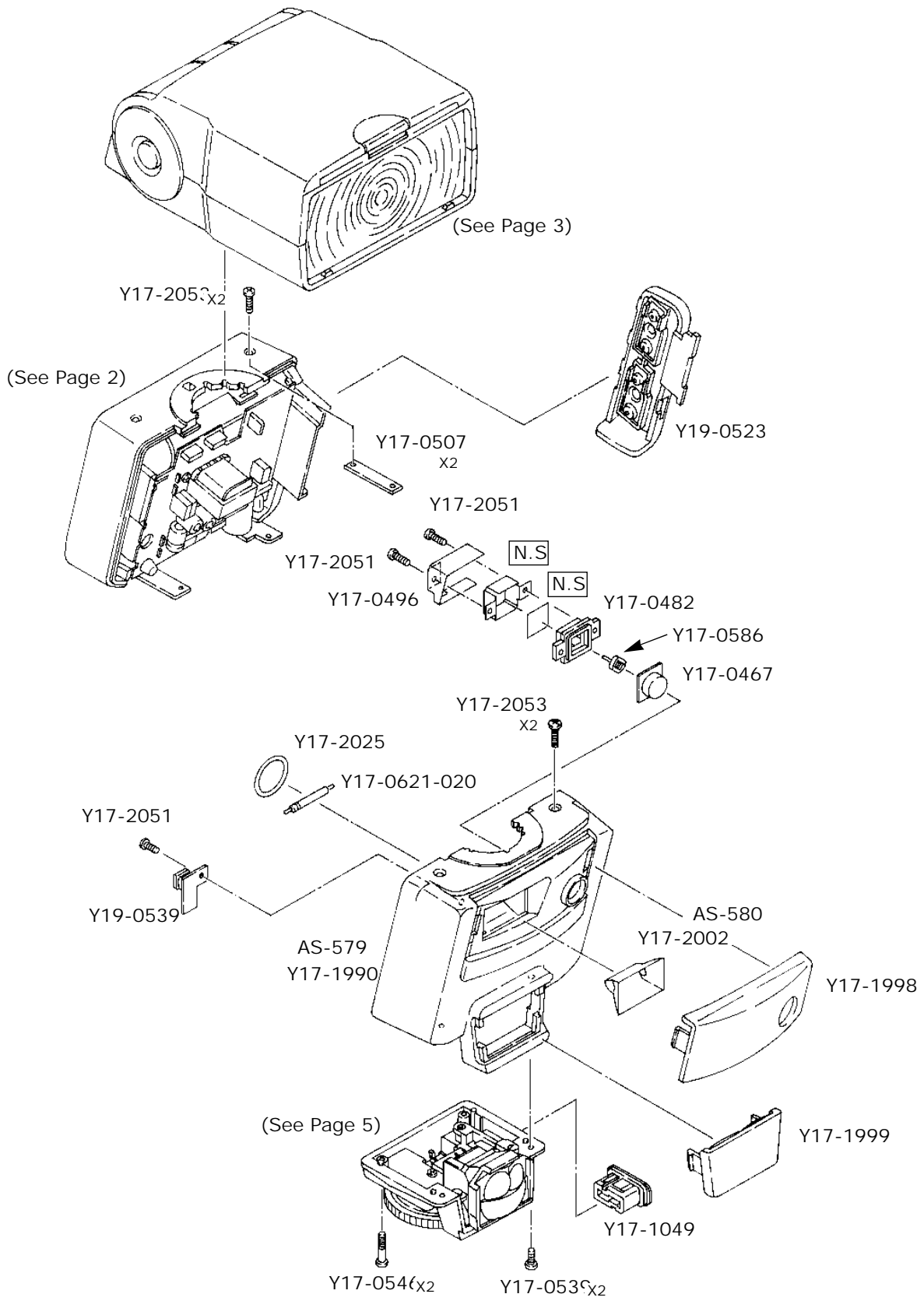

PARTS LIST

REF.NO.C50-0711,0712

Report.No.NEW	PARTS NO.	CLASS	QTY	DESCRIPTION
	Y17-0467-000	D	1	LENS, PD
	Y17-0482-000	E	1	HOLDER, PD
	Y17-0496-000	E	1	PLATE, SHIELD
	Y17-0507-000	E	2	PLATE
	Y17-0539-000		2	SCREW
	Y17-0546-000		2	SCREW
	Y17-0586-000	D	1	PHOTO-DIODE
	Y17-0621-020	D	1	LAMP, XENON(SUB)
	Y17-1049-000	D	1	CAP, DUST
AS-579	Y17-1990-000	D	1	COVER, BODY(F)
	Y17-1998-000	D	1	PANEL, PREFLASH
	Y17-1999-000	D	1	PANEL, AF LED
AS-580	Y17-2002-000	E	1	REFLECTOR
	Y17-2025-000	E	1	HOLDER, XENON
	Y17-2051-000		3	SCREW
	Y17-2053-000		4	SCREW
	Y19-0523-000	D	1	BATTERY COVER UNIT
	Y19-0539-000	D	1	(J)CBA

CANON SPEEDLITE 540EZ

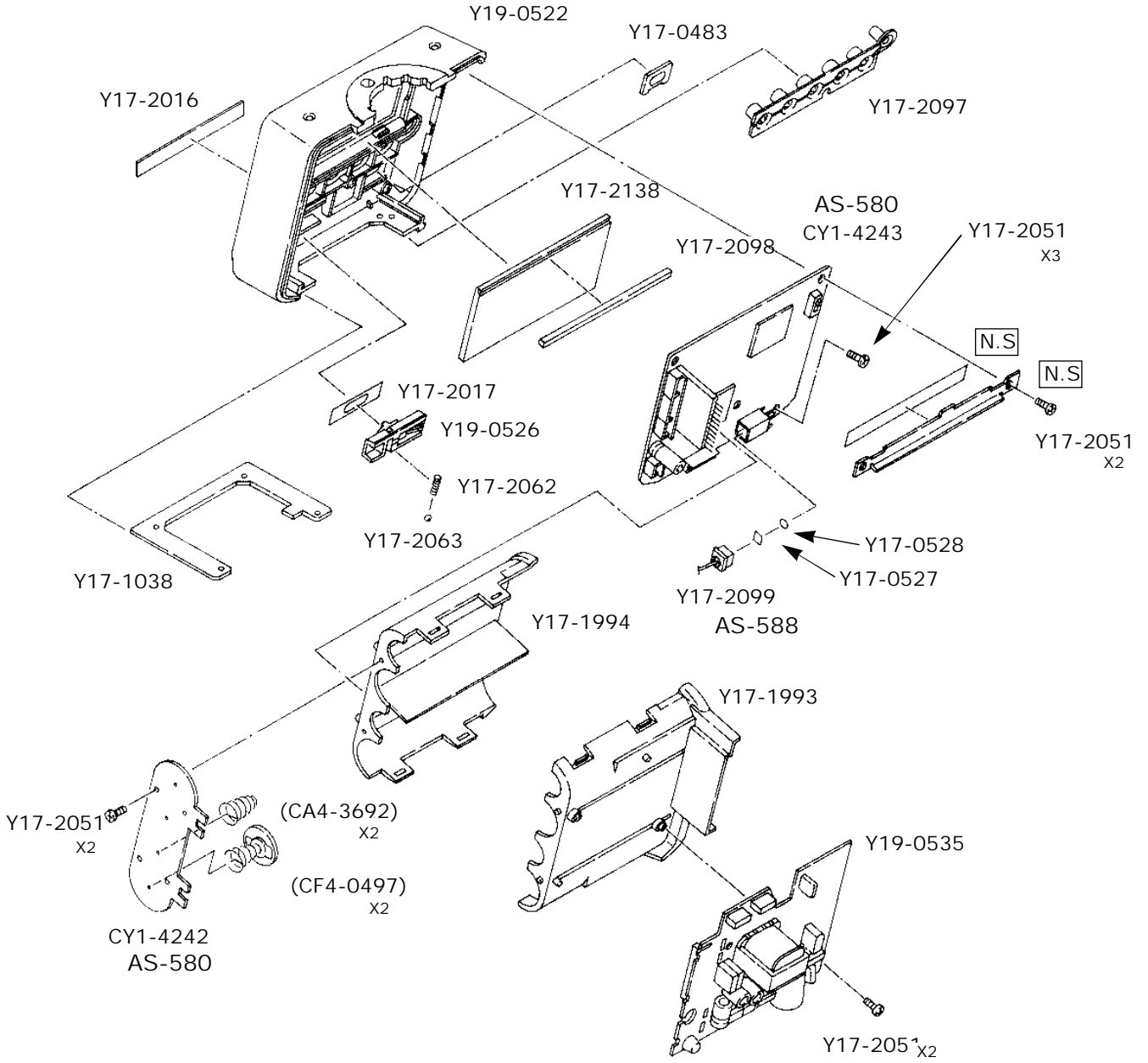

PARTS LIST

REF.NO.C50-0711,0712

Report.No.NEW	PARTS NO.	CLASS	QTY	DESCRIPTION
	CA4-3692-000	D	2	CONTACT, BATTERY
	CF4-0497-000	D	2	BATTERY CONTACT ASS'Y
AS-580	CY1-4242-000	D	1	(C)CBA
AS-580	CY1-4243-000	D	1	(A)CBA
	Y17-0483-000	D	1	BUTTON, TEST
	Y17-0527-000	D	1	FILTER
	Y17-0528-000	D	1	FILTER, ND
	Y17-1038-000	E	1	BASEPLATE
	Y17-1993-000	D	1	BOX(A), BATTERY
	Y17-1994-000	D	1	BOX(B), BATTERY
	Y17-2016-000	D	1	PLATE, BLIND
	Y17-2017-000	D	1	PLATE, MAIN SW
	Y17-2051-000		9	SCREW
	Y17-2062-000	E	1	SPRING, COIL
	Y17-2063-000	D	1	BALL
	Y17-2097-000	D	1	SWITCH, MODE
	Y17-2098-000	D	1	CONNECTOR, LCD
AS-588	Y17-2099-000	D	1	CONNECTOR, OPT
	Y17-2138-000	D	1	LCD DISPLAY
	Y19-0522-000	D	1	COVER, BODY(R)
	Y19-0526-000	D	1	MAIN SWITCH
	Y19-0535-000	D	1	(B)CBA

CANON SPEEDLITE 540EZ

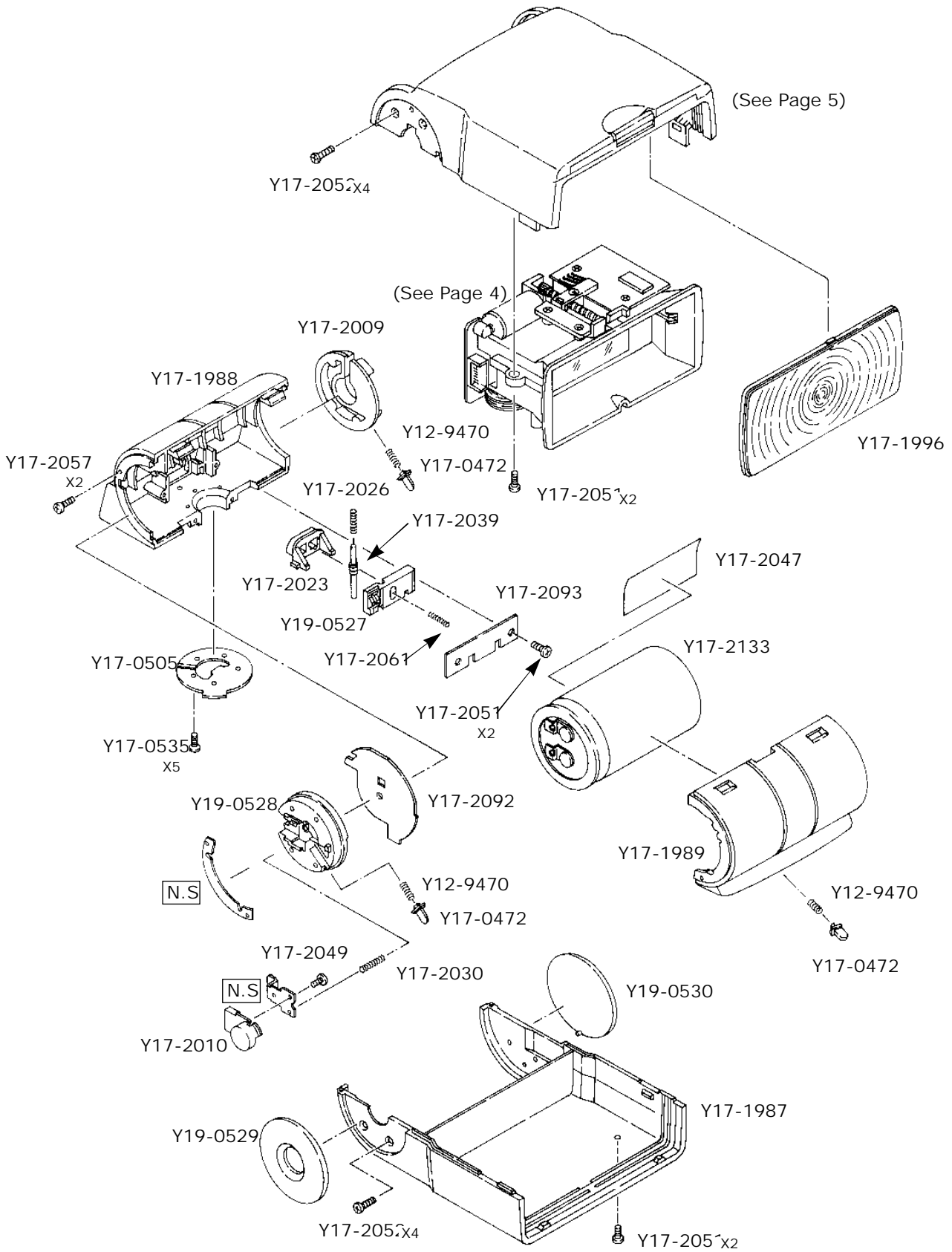

PARTS LIST

REF.NO.C50-0711,0712

Report.No.NEW	PARTS NO.	CLASS	QTY	DESCRIPTION
	Y12-9470-000	E	3	SPRING, COIL
	Y17-0472-000	D	3	PIN, CLICK
	Y17-0505-000	E	1	PLATE, DETENT
	Y17-0535-000		5	SCREW
	Y17-1987-000	D	1	COVER, FLASH(L)
	Y17-1988-000	D	1	COVER, PIVOT(R)
	Y17-1989-000	D	1	COVER, PIVOT(F)
	Y17-1996-000	D	1	PANEL, FRESNEL(MAIN)
	Y17-2009-000	E	1	WHEEL, PIVOT(R)
	Y17-2010-000	E	1	KNOB, BOUNCE LOCK(V)
	Y17-2023-000	D	1	KNOB, BOUNCE LOCK(H)
	Y17-2026-000	E	1	SPRING, COIL
	Y17-2030-000	E	1	SPRING, COIL
	Y17-2039-000	E	1	PIN, BOUNCE LOCK(H)
	Y17-2047-000	E	1	TAPE, DOUBLE-SIDED
	Y17-2049-000		1	SCREW
	Y17-2051-000		6	SCREW
	Y17-2052-000		8	SCREW
	Y17-2057-000		2	SCREW
	Y17-2061-000	E	1	SPRING, COIL
	Y17-2092-000	D	1	PCB, BOUNCE SW(V)
	Y17-2093-000	D	1	PCB, BOUNCE SW(H)
	Y17-2133-000	D	1	CAPACITOR, MAIN
	Y19-0527-000	D	1	SWITCH, BOUNCE(H)
	Y19-0528-000	D	1	WHEEL, PIVOT(L)
	Y19-0529-000	D	1	COVER, RUBBER(L)
	Y19-0530-000	D	1	COVER, RUBBER(R)

CANON SPEEDLITE 540EZ

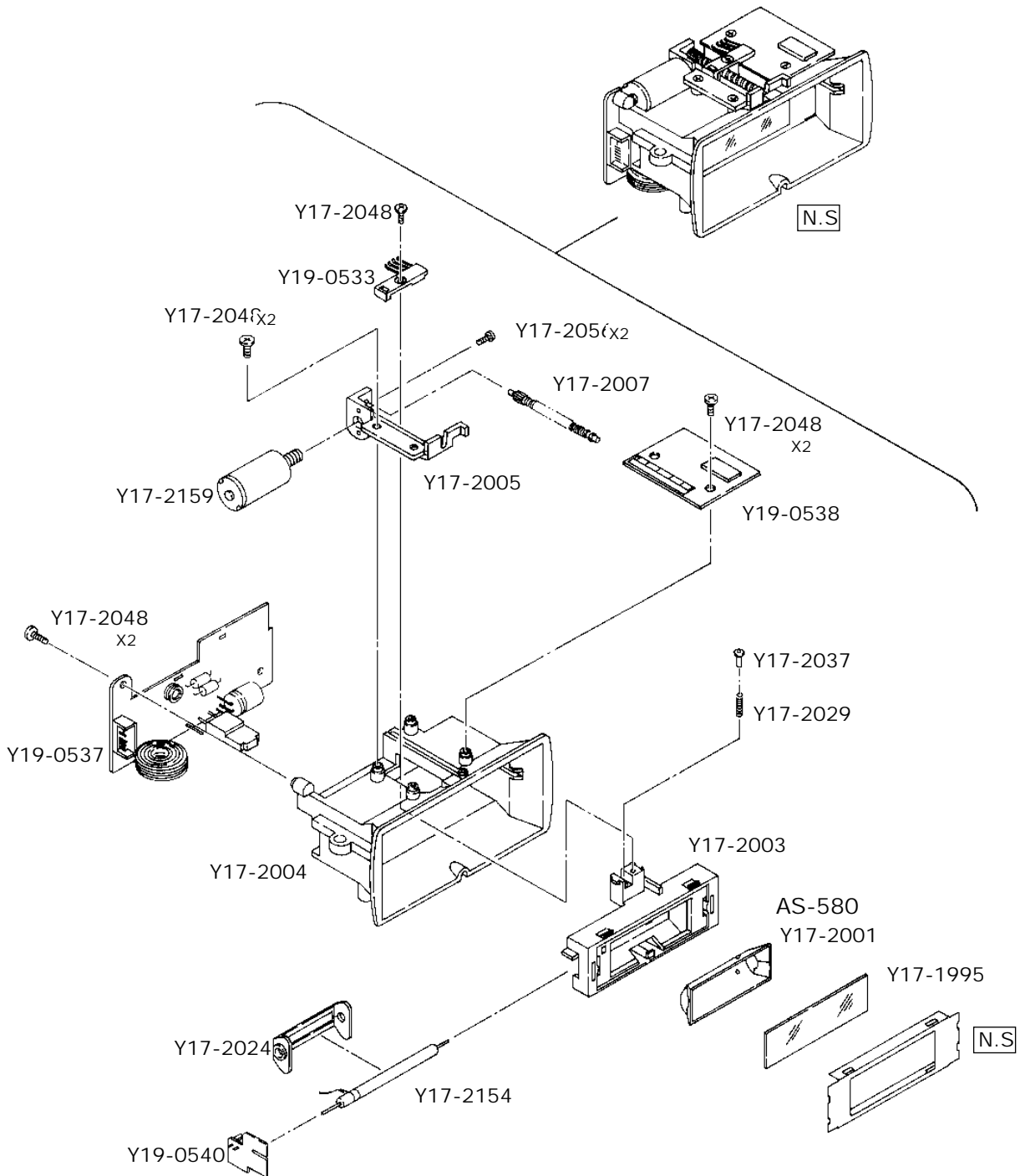

PARTS LIST

REF.NO.C50-0711,0712

Report.No.NEW	PARTS NO.	CLASS	QTY	DESCRIPTION
	Y17-1995-000	D	1	GRASS, FRONT
AS-580	Y17-2001-000	E	1	REFLECTOR
	Y17-2003-000	E	1	FRAME, MAIN LAMP
	Y17-2004-000	E	1	HOUSING, MAIN LAMP
	Y17-2005-000	E	1	HOLDER, ZOOM MOTOR
	Y17-2007-000	E	1	SHAFT, ZOOM
	Y17-2024-000	E	1	BUSH, MOUNTING
	Y17-2029-000	E	1	SPRING, COIL
	Y17-2037-000	E	1	PIN, ZOOM
	Y17-2048-000		7	SCREW
	Y17-2056-000		2	SCREW
	Y17-2154-000	D	1	LAMP, XENON(MAIN)
	Y17-2159-000	D	1	MOTOR, ZOOM
	Y19-0533-000	D	1	ZOOM SWITCH
	Y19-0537-000	D	1	(D)CBA
	Y19-0538-000	D	1	(E)CBA
	Y19-0540-000	D	1	(L)CBA

CANON SPEEDLITE 540EZ

• EWIDE PANEL

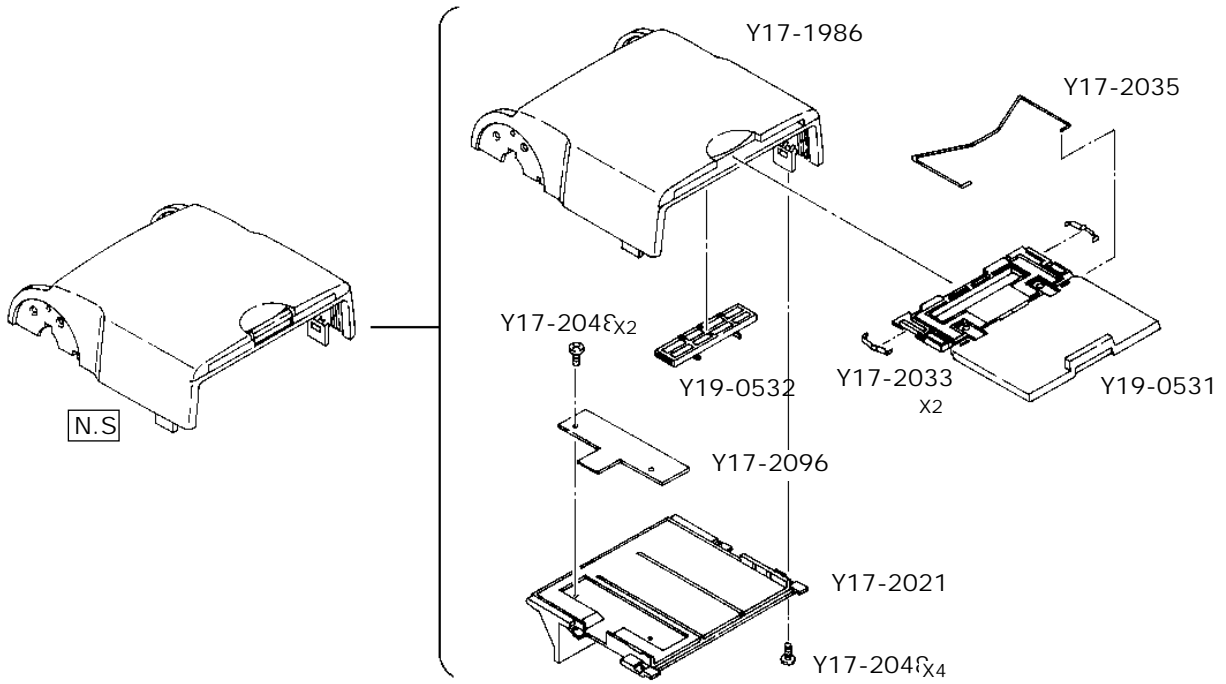

• ESHOE UNIT

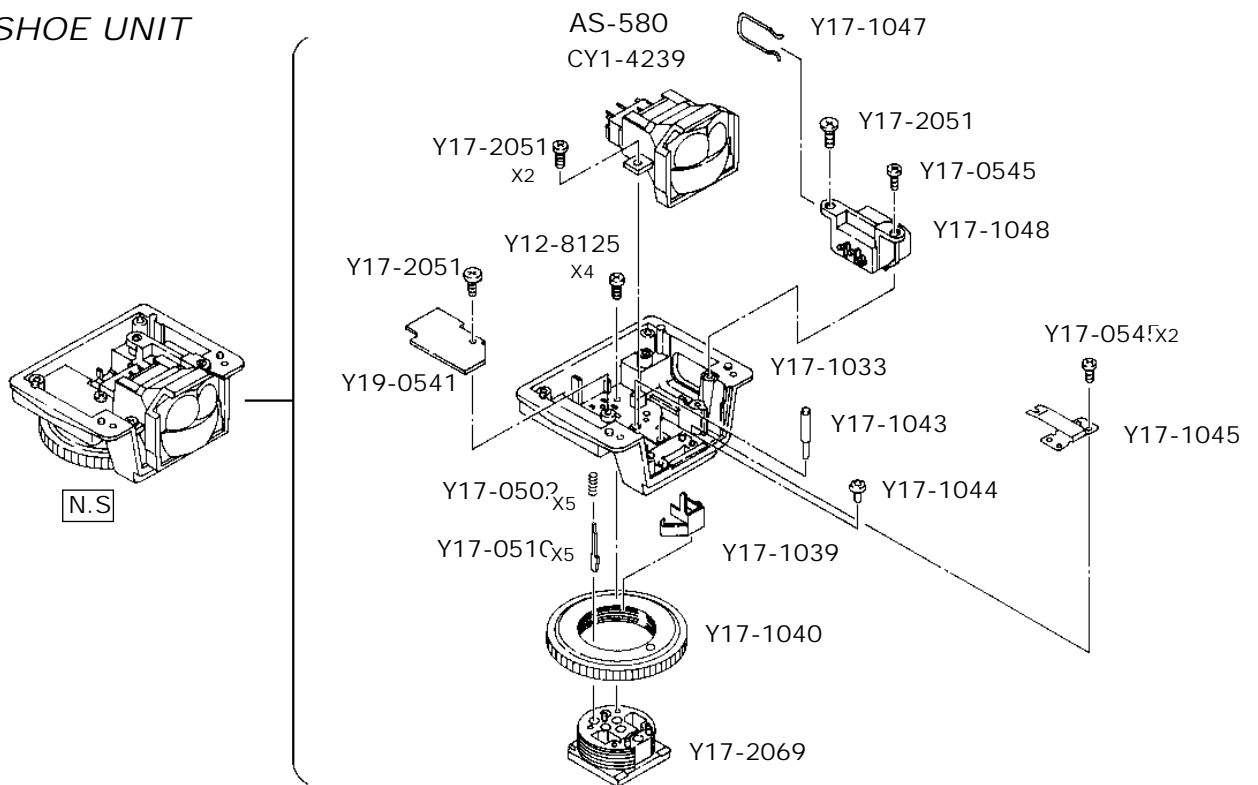

PARTS LIST

REF.NO.C50-0711,0712

Report.No.NEW	PARTS NO.	CLASS	QTY	DESCRIPTION
AS-580	CY1-4239-000	D	1	AF LED UNIT
	Y12-8125-000		4	SCREW
	Y17-0502-000	D	5	SPRING, COIL
	Y17-0510-000	D	5	CONTACT, SHOE
	Y17-0545-000		3	SCREW
	Y17-1033-000	D	1	CASE, SHOE
	Y17-1039-000	D	1	CONTACT, SHOE(-)
	Y17-1040-000	D	1	NUT, SHOE
	Y17-1043-000	D	1	PIN, SHOE LOCK
	Y17-1044-000	D	1	PIN, LOCK
	Y17-1045-000	D	1	CONTACT, SHOE LOCK
	Y17-1047-000	E	1	SPRING, CONNECTOR
	Y17-1048-000	E	1	CONNECTOR, POWER
	Y17-1986-000	D	1	COVER, FLASH(U)
	Y17-2021-000	E	1	HOLDER, WIDE PANEL
	Y17-2033-000	E	2	SPRING, CLICK
	Y17-2035-000	E	1	SPRING, WIDE PANEL
	Y17-2048-000		6	SCREW
	Y17-2051-000		4	SCREW
	Y17-2069-000	C	1	SHOE
	Y17-2096-000	D	1	PCB, WIDE PANEL SW
	Y19-0531-000	D	1	WIDE PANEL UNIT
	Y19-0532-000	D	1	SWITCH, WIDE PANEL
	Y19-0541-000	D	1	(H)CBA

ELECTRIC PARTS LIST

REF.NO.C50-0711,0712

Report.No.NEW	PARTS NO.	CLASS	DESCRIPTION	REMARK
	Y17-2171-000	1	LEAD ASS'Y, CN-1	fŠ• [fh• üfZfbfg(CN1)
	Y17-2172-000	1	LEAD ASS'Y, CN-2	fŠ• [fh• üfZfbfg(CN2)
	Y17-2174-000	1	LEAD ASS'Y, CN-4	fŠ• [fh• üfZfbfg(CN4)
	Y17-2175-000	1	LEAD ASS'Y, CN-6	fŠ• [fh• üfZfbfg(CN6)
	Y17-2176-000	1	LEAD ASS'Y, CN-7	fŠ• [fh• üfZfbfg(CN7)
	Y17-2177-000	1	LEAD ASS'Y, CN-8	fŠ• [fh• üfZfbfg(CN8)
	Y17-2178-000	1	LEAD ASS'Y, CN-9	fŠ• [fh• üfZfbfg(CN9)
	Y17-2179-000	1	LEAD ASS'Y, CN-10	fŠ• [fh• üfZfbfg(CN10)
	Y17-2180-000	1	LEAD ASS'Y, CN-11	fŠ• [fh• üfZfbfg(CN11)
	Y17-2181-000	1	LEAD ASS'Y, CN-12	fŠ• [fh• üfZfbfg(CN12)
	Y17-2182-000	1	LEAD ASS'Y, CN-13	fŠ• [fh• üfZfbfg(CN13)
	Y17-2183-000	1	LEAD ASS'Y, CN-14	fŠ• [fh• üfZfbfg(CN14)
	Y17-2184-000	1	LEAD ASS'Y, CN-15	fŠ• [fh• üfZfbfg(CN15)
	Y17-2185-000	1	LEAD ASS'Y, CN-16	fŠ• [fh• üfZfbfg(CN16)

ATTENTION: these documentations are published only for purpose of study and search, they are **not published for purpose of profit**, all the rights and relative copyrights are of the respective owners. **Free documentation not to sell.**