

SPEEDLITE 550EX

C50-0731

PARTS CATALOG

ATTENTION: these documentations are published only for purpose of study and search, they are not published for purpose of profit, all the rights and relative copyrights are of the respective owners. **Free documentation not to sell.**

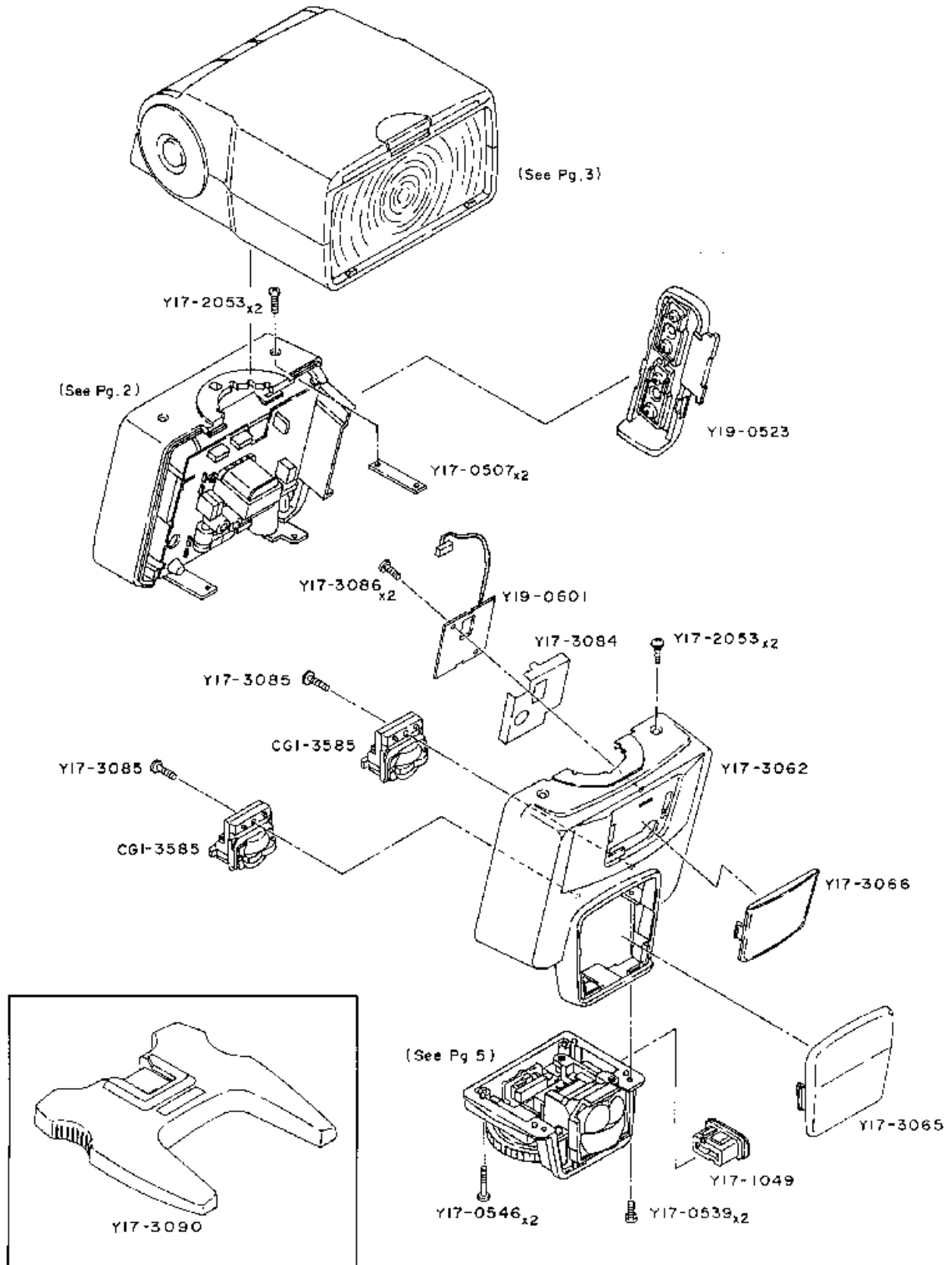

PARTS LIST

REF.NO.C50-0731

Report.No.NEW	PARTS NO.	CLASS	QTY	DESCRIPTION
	CG1-3585-000	D	2	LED UNIT, AF
	Y17-0507-000	E	2	PLATE
	Y17-0539-000		2	SCREW
	Y17-0546-000		2	SCREW
	Y17-1049-000	D	1	CAP, DUST
	Y17-2053-000		4	SCREW
	Y17-3062-000	C	1	COVER, FRONT
	Y17-3065-000	C	1	PANEL, AF LED
	Y17-3066-000	C	1	PANEL, PREFLASH
	Y17-3084-000	E	1	PLATE, SHIELD
	Y17-3085-000		2	SCREW
	Y17-3086-000		2	SCREW
	Y17-3090-000	E	1	STAND, ACC
	Y19-0523-000	D	1	BATTERY COVER UNIT
	Y19-0601-000	D	1	PCB ASS'Y(I)

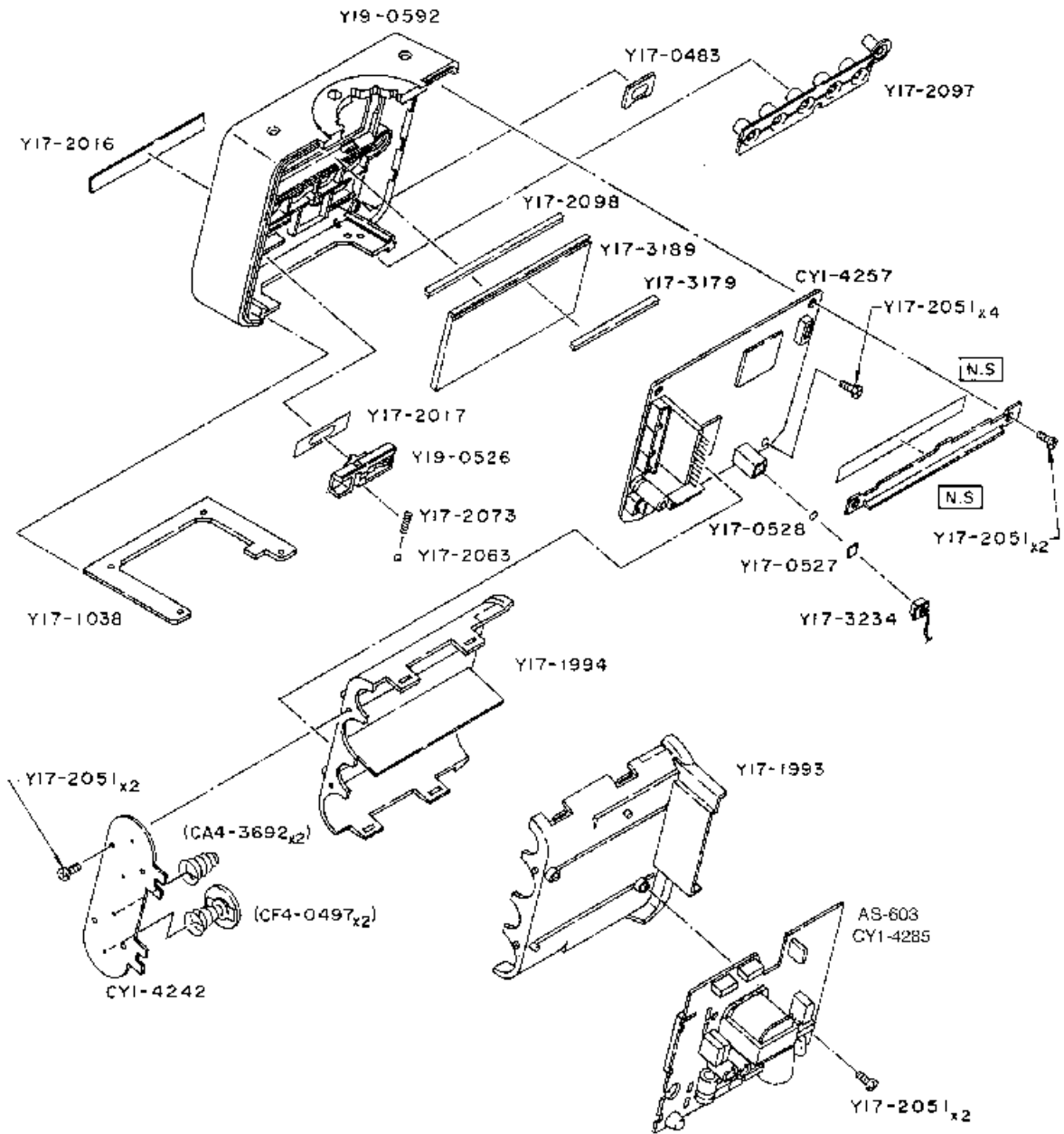

PARTS LIST

REF.NO.C50-0731

Report.No.NEW	PARTS NO.	CLASS	QTY	DESCRIPTION
	CA4-3692-000	D	2	CONTACT, BATTERY
	CF4-0497-000	D	2	BATTERY CONTACT ASS'Y
	CY1-4242-000	D	1	PCB ASS'Y(C)
	CY1-4257-000	D	1	PCB ASS'Y(A)
AS-603	CY1-4285-000	D	1	PCB ASS'Y(B)
	Y17-0483-000	D	1	BUTTON, TEST
	Y17-0527-000	D	1	FILTER
	Y17-0528-000	D	1	FILTER, ND
	Y17-1038-000	E	1	PLATE, BASE
	Y17-1993-000	D	1	BOX(A), BATTERY
	Y17-1994-000	D	1	BOX(B), BATTERY
	Y17-2016-000	D	1	PLATE, BLIND
	Y17-2017-000	D	1	PLATE, MAIN SW
	Y17-2051-000		10	SCREW
	Y17-2063-000	D	1	BALL
	Y17-2073-000	E	1	SPRING, COIL
	Y17-2097-000	D	1	SWITCH, MODE
	Y17-2098-000	D	1	CONNECTOR, LCD
	Y17-3179-000	D	1	CONNECTOR, LCD
	Y17-3189-000	D	1	LCD
	Y17-3234-000	D	1	CONNECTOR, OPT
	Y19-0526-000	D	1	MAIN SWITCH
	Y19-0592-000	D	1	REAR COVER ASS'Y

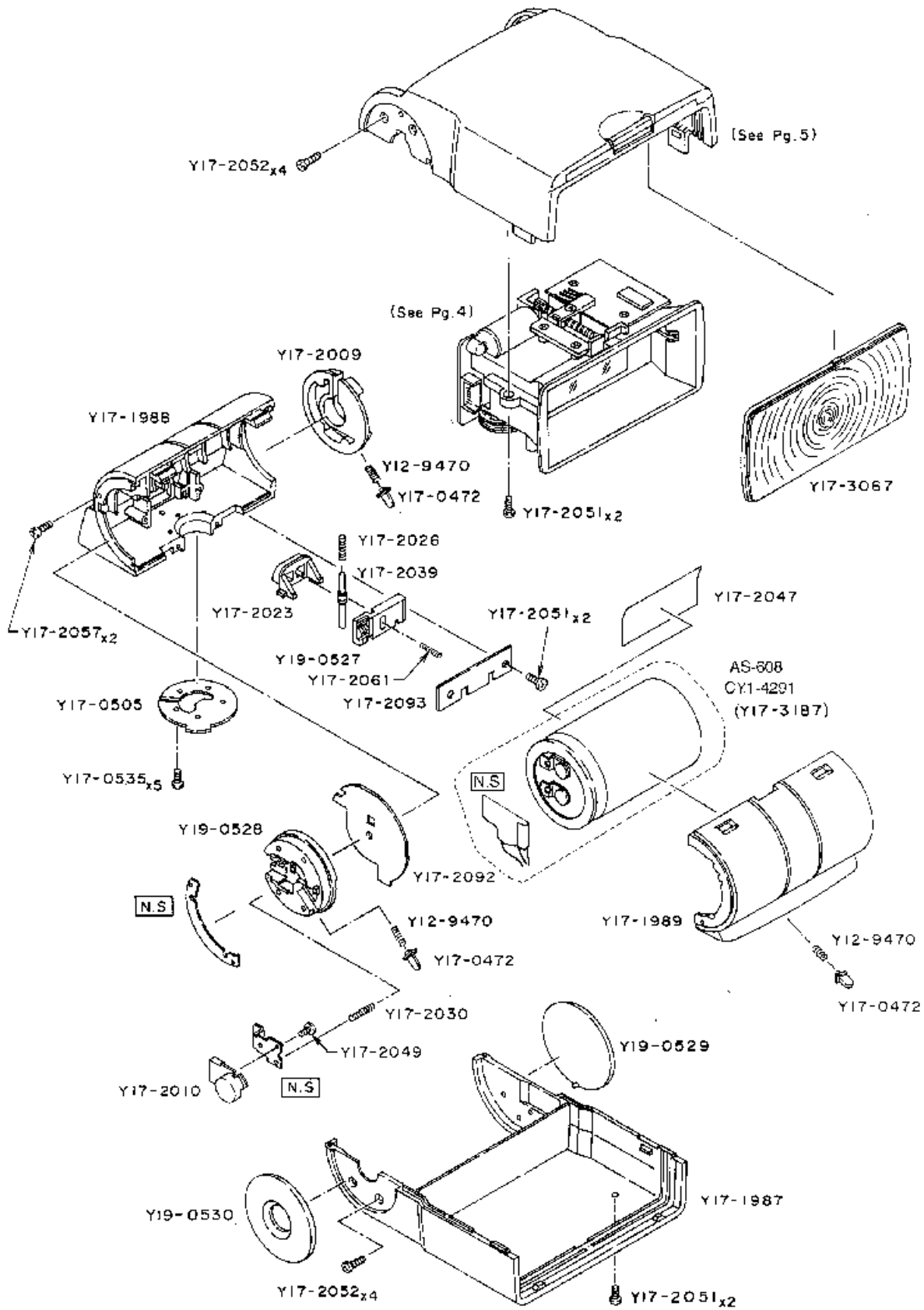

PARTS LIST

REF.NO.C50-0731

Report.No.NEW	PARTS NO.	CLASS	QTY	DESCRIPTION
AS-608	CY1-4291-000	D	1	CAPACITOR ASS'Y, MAIN
	Y12-9470-000	E	3	SPRING, COIL
	Y17-0472-000	D	3	PIN, CLICK
	Y17-0505-000	E	1	PLATE, DETENT
	Y17-0535-000		5	SCREW
	Y17-1987-000	D	1	COVER, FLASH(L)
	Y17-1988-000	D	1	COVER, PIVOT(R)
	Y17-1989-000	D	1	COVER, PIVOT(F)
	Y17-2009-000	E	1	WHEEL, PIVOT(R)
	Y17-2010-000	E	1	KNOB, BOUNCE LOCK(V)
	Y17-2023-000	D	1	KNOB, BOUNCE LOCK(H)
	Y17-2026-000	E	1	SPRING, COIL
	Y17-2030-000	E	1	SPRING, COIL
	Y17-2039-000	E	1	PIN, BOUNCE LOCK(H)
	Y17-2047-000	E	1	TAPE, DOBLE-SIDED
	Y17-2049-000		1	SCREW
	Y17-2051-000		6	SCREW
	Y17-2052-000		8	SCREW
	Y17-2057-000		2	SCREW
	Y17-2061-000	E	1	SPRING, COIL
	Y17-2092-000	D	1	PCB, BOUNCE SW(V)
	Y17-2093-000	D	1	PCB, BOUNCE SW(H)
	Y17-3067-000	D	1	PANEL, FRESNEL(MAIN)
	{Y17-3187-000}	D	1	CAPACITOR, MAIN
	Y19-0527-000	D	1	SWITCH, BOUNCE(H)
	Y19-0528-000	D	1	WHEEL, PIVOT(L)
	Y19-0529-000	D	1	COVER, RUBBER(L)
	Y19-0530-000	D	1	COVER, RUBBER(R)

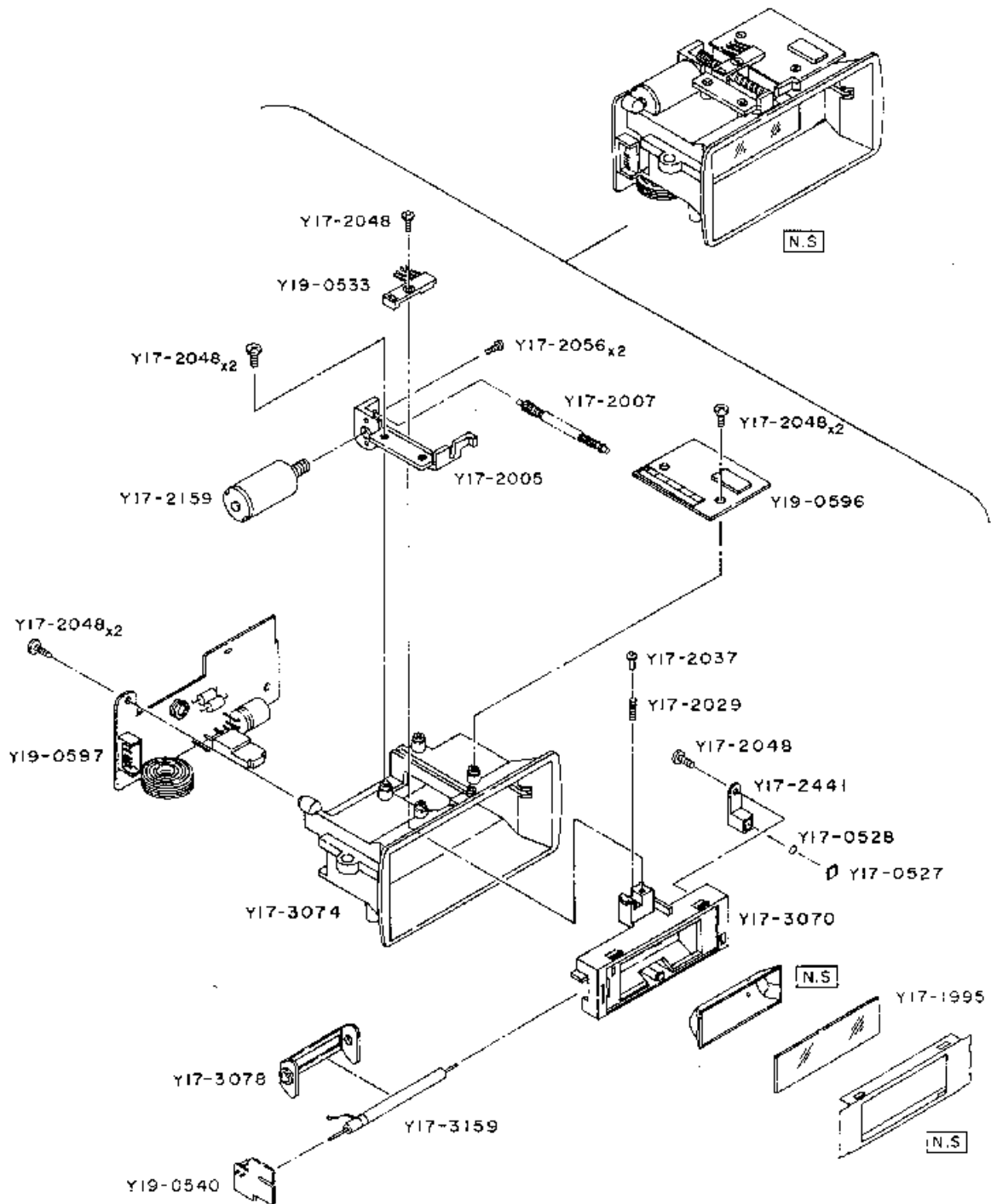

PARTS LIST

REF.NO.C50-0731

Report.No.NEW	PARTS NO.	CLASS	QTY	DESCRIPTION
	Y17-0527-000	D	1	FILTER, OPTICAL
	Y17-0528-000	D	1	FILTER, ND
	Y17-1995-000	D	1	GLASS, FRONT
	Y17-2005-000	E	1	HOLDER, ZOOM MOTOR
	Y17-2007-000	E	1	SHAFT, ZOOM
	Y17-2029-000	E	1	SPRING, COIL
	Y17-2037-000	E	1	PIN, ZOOM
	Y17-2048-000		8	SCREW
	Y17-2056-000		2	SCREW
	Y17-2159-000	D	1	MOTOR, ZOOM
	Y17-2441-000	E	1	CASE, SENSOR
	Y17-3070-000	E	1	FRAME, MAIN LAMP
	Y17-3074-000	E	1	HOUSING, MAIN LAMP
	Y17-3078-000	E	1	BUSH, MOUNTING
	Y17-3159-000	D	1	LAMP, XENON(MAIN)
	Y19-0533-000	D	1	ZOOM SWITCH
	Y19-0540-000	D	1	PCB ASS'Y(L)
	Y19-0596-000	D	1	PCB ASS'Y(E)
	Y19-0597-000	D	1	PCB ASS'Y(D)

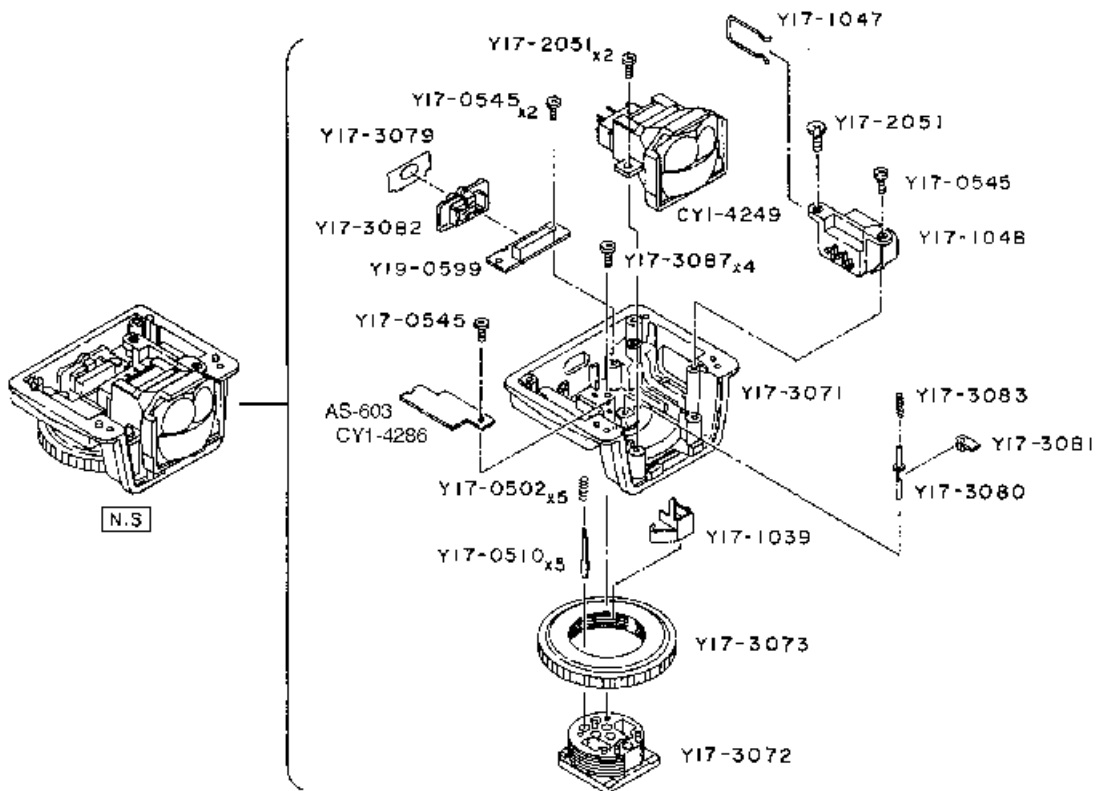
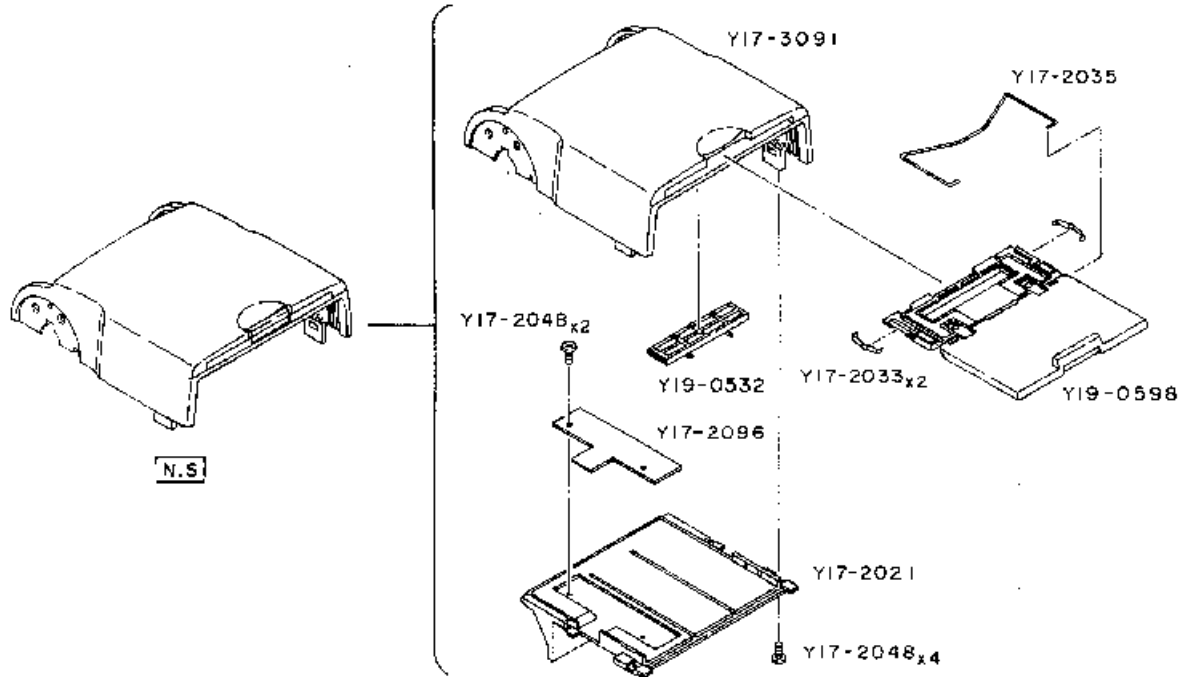

PARTS LIST

REF.NO.C50-0731

Report.No.NEW	PARTS NO.	CLASS	QTY	DESCRIPTION
	CY1-4249-000	D	1	AF LED UNIT
AS-603	CY1-4286-000	D	1	PCB ASS'Y(O)
	Y17-0502-000	D	5	SPRING COIL
	Y17-0510-000	D	5	CONTACT, SHOE
	Y17-0545-000		4	SCREW
	Y17-1039-000	D	1	CONTACT, SHOE(-)
	Y17-1047-000	E	1	SPRING, CONNECTOR
	Y17-1048-000	E	1	CONNECTOR, POWER
	Y17-2021-000	E	1	HOLDER, WIDE PANEL
	Y17-2033-000	E	2	SPRING, CLICK
	Y17-2035-000	E	1	SPRING, WIDE PANEL
	Y17-2048-000		6	SCREW
	Y17-2051-000		2	SCREW
	Y17-2096-000	D	1	PCB, WIDE PANEL SW
	Y17-3071-000	D	1	CASE, SHOE
	Y17-3072-000	C	1	SHOE
	Y17-3073-000	D	1	NUT, SHOE
	Y17-3079-000	D	1	PLATE, SELECT SW
	Y17-3080-000	E	1	PIN, SHOE LOCK
	Y17-3081-000	E	1	KNOB, SWITCH
	Y17-3082-000	D	1	SWITCH, WIRELESS SELECT
	Y17-3083-000	D	1	SPRING, SHOE LOCK
	Y17-3087-000		4	SCREW
	Y17-3091-000	D	1	COVER, FLASH(U)
	Y19-0532-000	D	1	SWITCH, WIDE PANEL
	Y19-0598-000	D	1	WIDE PANEL UNIT
	Y19-0599-000	D	1	PCB ASS'Y(N)

ATTENTION: these documentations are published only for purpose of study and search, they are not published for purpose of profit, all the rights and relative copyrights are of the respective owners. **Free documentation not to sell.**